

Pitch 3/8" x 3/16"

for roller chains in compliance with
DIN 8188-ISO/R 606 - ANSI B 29.1

SPROCKET

	mm
TOOTH RADIUS r_3	10
RADIUS WIDTH C	1.2
SPROCKET TOOTH WIDTH B_1	4.4
SPROCKET TOOTH WIDTH b_1	4.3
SPROCKET TOOTH WIDTH B_2	14.4

CHAIN

	mm
PITCH	9.525
INTERNAL WIDTH	4.77
ROLLER - \emptyset	5.08

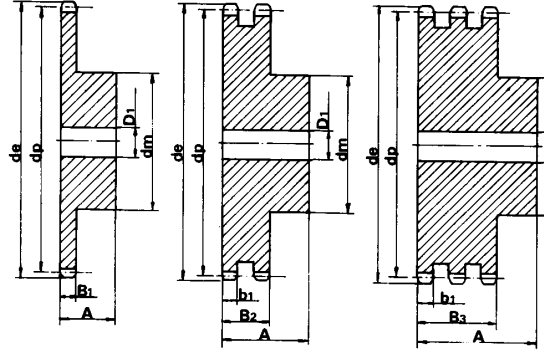

MATERIAL: C 45 UNI 7845 SPROCKETS

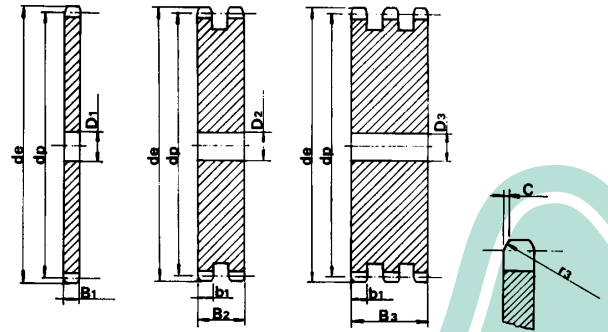

Pitch 3/8" x 3/16"

for roller chains in compliance with
DIN 8188-ISO/R 606 - ANSI B 29.1

PLATEWHEEL

	mm
TOOTH RADIUS r_3	13.5
RADIUS WIDTH C	1.6
PLATE TOOTH WIDTH B_1	7.4
PLATE TOOTH WIDTH b_1	7.2
PLATE TOOTH WIDTH B_2	21.6
PLATE TOOTH WIDTH B_3	36

CHAIN

	mm
PITCH	12.7
INTERNAL WIDTH	7.94
ROLLER - \emptyset	7.94

MATERIAL C 45 UNI 7845 SPROCKETS

SPROCKETS

Z	d_e	d_p	SINGLE			DOUBLE		
			d_m	D_1	A	d_m	D_1	A
10	35.70	30.82	20	8	22			
11	38.69	33.80	22	8	25			
12	41.68	36.80	25	8	25			
13	44.68	39.80	28	10	25	28	10	25
14	47.68	42.80	31	10	25	31	10	25
15	50.69	45.81	34	10	25	34	10	25
16	53.70	48.82	37	10	28	37	12	30
17	56.72	51.83	38	10	28	40	12	30
18	59.73	54.85	38	10	28	43	12	30
19	62.75	57.87	46	10	28	46	12	30
20	65.77	60.89	46	10	28	49	12	30
21	68.79	63.91	46	10	28	52	12	30
22	71.81	66.93	52	12	28	55	12	30
23	74.83	69.95	52	12	28	58	12	30
24	77.85	72.97	52	12	28	61	12	30
25	80.88	76.00	58	12	28	64	12	30
26	83.90	79.02	58	12	28	67	12	30
27	86.93	82.04	58	12	28	70	12	30
28	89.95	85.07	60	12	28	73	12	30
30	96.00	91.12	60	12	28			

PLATEWHEELS

Z	d_e	d_p	S D T		
			D_1	D_2	D_3
30	96.00	91.12		12	
32	102.06	97.17	12		
36	114.17	109.29	12		
38	120.22	115.34	12	14	
40	126.28	121.40	12		
45	141.43	136.55	16	16	
48	150.52	145.64	16		
57	177.79	172.91	16	16	
76	235.37	230.49	20	20	

SPROCKETS

Z	d_e	d_p	SINGLE			DOUBLE			TRIPLE		
			d_m	D_1	A	d_m	D_1	A	d_m	D_1	A
10	47.66	41.10	26	10	25						
11	51.64	45.08	29	10	25						
12	55.63	49.07	35	10	28						
13	59.63	53.07	35	10	28	38	12	35	35	14	50
14	63.63	57.07	35	10	28	42	12	35	42	14	50
15	67.64	61.08	46	10	28	46	12	35	46	14	50
16	71.66	65.10	48	10	28	50	14	35	50	16	50
17	75.68	69.12	48	10	28	54	14	35	54	16	50
18	79.70	73.14	58	12	28	58	14	35	58	16	50
19	83.72	77.16	60	12	28	62	14	35	62	16	50
20	87.74	81.18	60	12	28	66	14	35	66	16	50
21	91.77	85.21	65	12	28	70	16	40	70	20	55
22	95.80	89.24	65	12	28	70	16	40	70	20	55
23	99.83	93.27	65	12	28	70	16	40	70	20	55
24	103.86	97.30	70	14	28	75	16	40	75	20	55
25	107.89	101.33	70	14	28	80	16	40	80	20	55
26	111.92	105.36	70	14	28	85	20	40	85	20	55
27	115.96	109.40	70	16	30	85	20	40	85	20	55
28	119.99	113.43	70	16	30	90	20	40	90	20	55
30	128.06	121.50	80	16	30	100	20	40			
32	136.13	129.57	80	16	30						
35	148.24	141.68	90	16	30						
36	152.28	145.72	90	16	30						
38	160.35	153.79	90	16	35						
40	168.43	161.87	90	16	35						

PLATEWHEELS

Z	d_e	d_p	S D T		
			D_1	D_2	D_3
30	128.06	121.50			20
32	136.13	129.57		16	
38	160.35	153.79		20	25
40	168.43	161.87		20	
42	176.50	169.94	20		
45	188.62	182.06	20	20	25
48	200.74	194.18	20		
57	237.10	230.54	20	25	25
76	313.88	307.32	25	25	25
95	390.67	384.11	25		