

S P R O C K E T S

Z	d _e	d _p	SINGLE		
			d _m	D ₁	A
8	18.0	15.67	9.8	5	10
9	19.9	7.54	11.5	5	10
10	21.7	19.42	13	6	10
11	23.6	21.30	14	6	10
12	25.4	23.18	16	6	10
13	27.3	25.05	18	8	10
14	29.2	26.96	20	8	10
15	31.0	28.86	20	8	10
16	33.0	30.76	20	8	13
17	35.0	32.65	20	8	13
18	36.9	34.55	20	8	13
19	38.8	36.44	20	8	13
20	40.7	38.34	20	8	13
21	42.6	40.25	25	8	13
22	44.5	42.16	25	8	13
23	46.4	44.06	25	8	13
24	48.3	45.96	25	8	13
25	50.2	47.87	25	8	13
26	52.1	49.76	30	8	15
27	54.0	51.67	30	8	15
28	55.9	53.58	30	8	15
29	57.8	55.50	30	8	15
30	59.8	57.42	30	8	15
31	61.7	59.31	30	8	15
32	63.6	61.21	30	8	15
33	65.5	63.11	30	8	15
34	67.4	65.02	30	8	15
35	69.3	66.93	30	8	15
36	71.2	68.84	30	8	15
37	73.1	70.75	30	8	15
38	75.0	72.66	30	8	15
39	76.9	74.57	30	8	15
40	78.9	76.47	30	8	15
45	88.5	86.01	40	10	16
50	98.0	95.55	50	12	20
57	111.4	108.93	50	12	20
76	147.6	145.19	60	12	20

6 x 2.8 mm

for roller chains in compliance with DIN 8187 ISO/R 606

the disc size is increased by h = 4mm for Z.57 and Z.76

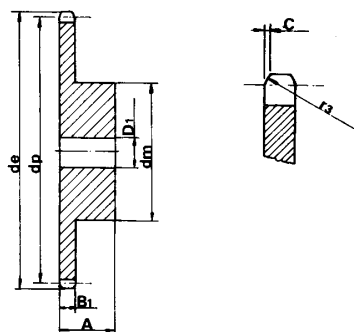

SPROCKET mm

TOOTH RADIUS r ₃	6
RADIUS WIDTH C	0.7
SPROCKET TOOTH WIDTH B ₁	2.6

CHAIN mm

PASSO	6
LARGHEZZA INTERNA	2.8
ROLLER - Ø	4

MATERIAL: C 45 UNI 7847

P L A T E W H E E L S

Z	d _e	d _p	S				
			D ₁	Z	d _e	d _p	D ₁
8	18.0	15.67	5	44	86.6	84.10	10
9	19.9	17.54	5	45	88.5	86.01	10
10	21.7	19.42	6	46	90.4	87.92	10
11	23.6	21.30	6	47	92.3	89.93	10
12	25.4	23.18	6	48	94.2	91.74	10
13	27.3	25.05	8	49	96.1	93.64	10
14	29.2	26.96	8	50	98.0	95.55	10
15	31.0	28.86	8	51	99.9	97.46	12
16	33.0	30.76	8	52	101.8	99.37	12
17	35.0	32.65	8	53	103.7	101.27	12
18	36.9	34.55	8	54	105.6	103.17	12
19	38.8	36.44	8	55	107.6	105.08	12
20	40.7	38.34	8	56	109.5	107.00	12
21	42.6	40.25	8	57	111.4	108.93	12
22	44.5	42.16	8	58	113.3	110.82	12
23	46.4	44.06	8	59	115.2	112.71	12
24	48.3	45.96	8	60	117.1	114.62	12
25	50.2	47.87	8	62	120.9	118.45	14
26	52.1	49.76	8	64	124.7	122.27	14
27	54.0	51.67	8	65	126.6	124.18	14
28	55.9	53.58	8	66	128.5	126.09	14
29	57.8	55.50	8	68	132.4	129.91	14
30	59.8	57.42	8	70	136.2	133.73	14
31	61.7	59.31	8	72	140.0	137.55	16
32	63.6	61.21	8	75	145.7	143.28	16
33	65.5	63.11	8	76	147.6	145.19	16
34	67.4	65.02	8	78	151.5	149.01	16
35	69.3	66.93	8	80	155.3	152.82	16
36	71.2	68.84	8	85	164.8	162.37	16
37	73.1	70.75	8	90	174.4	171.92	16
38	75.0	72.66	8	95	183.9	181.47	16
39	76.9	74.57	8	100	193.5	191.01	16
40	78.9	76.47	8	110	212.6	210.11	16
41	80.8	78.38	10	114	220.2	217.75	16
42	82.7	80.28	10	120	231.7	229.20	16
43	84.7	82.19	10	125	241.2	238.75	16

6 x 2.8 mm

for roller chains in compliance with DIN 8187 ISO/R 606

The wheel disc size is increased by h = 4mm starting from Z.51

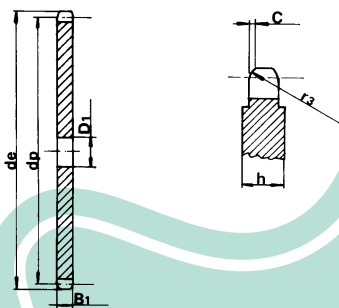

PLATEWHEEL mm

TOOTH RADIUS r ₃	6
RADIUS WIDTH C	0.7
PLATE TOOTH WIDTH B ₁	2.6

CHAIN mm

PITCH	6
INTERNAL WIDTH	2.8
ROLLER - Ø	4