

# S P R O C K E T S

## SINGLE

Z	d <sub>e</sub>	d <sub>p</sub>	d <sub>m</sub>	D <sub>1</sub>	A
8	38.5	33.18	20	10	25
9	41.5	37.13	24	10	25
10	46.2	41.10	26	10	25
11	49.6	45.07	29	10	25
12	53.9	49.07	33	10	28
13	58.4	53.06	37	10	28
14	62.8	57.07	41	10	28
15	66.8	61.09	45	10	28
16	70.9	65.10	50	12	28
17	74.9	69.11	52	12	28
18	78.9	73.14	56	12	28
19	82.9	77.16	60	12	28
20	86.9	81.19	64	12	28
21	91.0	85.22	68	14	28
22	95.0	89.24	70	14	28
23	99.0	93.27	70	14	28
24	103.0	97.29	70	14	28
25	107.1	101.33	70	14	28
26	111.2	105.36	70	16	30
27	115.4	109.40	70	16	30
28	119.4	113.42	70	16	30
29	123.4	117.46	80	16	30
30	127.5	121.50	80	16	30
31	131.5	125.54	90	16	30
32	135.5	129.56	90	16	30
33	139.6	133.60	90	16	30
34	143.6	137.64	90	16	30
35	147.6	141.68	90	16	30
36	151.7	145.72	90	16	35
37	155.7	149.76	90	16	35
38	159.8	153.80	90	16	35
39	163.8	157.83	90	16	35
40	167.8	161.87	90	16	35

Sprocket sizes subject to availability

**1/2" x 1/4" - 7.75 roller size**  
for roller chains in compliance with DIN 8187 ISO/R 606

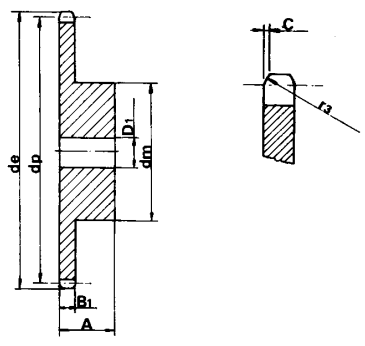

### SPROCKET mm

TOOTH RADIUS r <sub>3</sub>	13
RADIUS WIDTH C	1.3
SPROCKET TOOTH WIDTH B <sub>1</sub>	5.9

### CHAIN mm

PITCH	12.7
INTERNAL WIDTH	6.4
ROLLER - ø	7.75

MATERIAL :C 45 UNI 7847

# P L A T E W H E E L S

## S

Z	d <sub>e</sub>	d <sub>p</sub>	D <sub>1</sub>
8	38.5	33.18	8
9	41.5	37.13	8
10	46.2	41.10	8
11	49.6	45.07	8
12	53.9	49.07	8
13	58.4	53.06	8
14	62.8	57.07	8
15	66.8	61.09	8
16	70.9	65.10	10
17	74.9	69.11	10
18	78.9	73.14	10
19	82.9	77.16	10
20	86.9	81.19	10
21	91.0	85.22	10
22	95.0	89.24	10
23	99.0	93.27	10
24	103.0	97.29	10
25	107.1	101.33	10
26	111.2	105.36	12
27	115.4	109.40	12
28	119.4	113.42	12
29	123.4	117.46	12
30	127.5	121.50	12
31	131.5	125.54	12
32	135.5	129.56	12
33	139.6	133.60	12
34	143.6	137.64	12
35	147.6	141.68	12
36	151.7	145.72	16
37	155.7	149.76	16
38	159.8	153.80	16
39	163.8	157.83	16
40	167.8	161.87	16
41	171.4	165.91	16
42	175.4	169.95	16

## S

Z	d <sub>e</sub>	d <sub>p</sub>	D <sub>1</sub>
43	179.5	173.99	16
44	183.5	178.03	16
45	187.5	182.07	16
46	191.6	186.10	20
47	195.6	190.14	20
48	199.7	194.18	20
49	203.7	198.22	20
50	207.8	202.26	20
51	211.8	206.30	20
52	215.9	210.34	20
53	219.9	214.37	20
54	224.0	218.43	20
55	228.0	222.46	20
56	232.1	226.50	20
57	236.1	230.54	20
58	240.2	234.58	20
59	244.2	238.62	20
60	248.2	242.66	20
62	256.7	250.75	20
64	264.8	258.82	20
65	268.8	262.86	20
66	272.9	266.90	25
68	280.9	274.99	25
70	289.0	283.07	25
72	297.1	291.16	25
76	313.3	307.33	25
78	321.4	315.40	25
80	329.4	323.48	25
85	349.7	343.70	25
90	369.9	363.90	25
95	390.1	384.10	25
100	410.3	404.31	25
110	450.7	444.74	25
114	466.9	460.90	25
120	491.2	485.16	25
125	511.4	505.37	25

**1/2" x 1/4" - 7.75 roller**  
for roller chains in compliance with DIN 8187 ISO/R 606

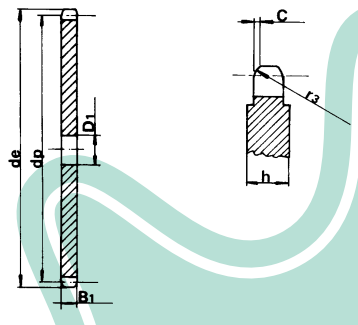

### PLATEWHEEL mm

TOOTH RADIUS r <sub>3</sub>	13
RADIUS WIDTH C	1.3
PLATE TOOTH WIDTH B <sub>1</sub>	5.9

### CHAIN mm

PITCH	12.7
INTERNAL WIDTH	6.4
ROLLER - ø	7.75